

GENERAL DESCRIPTION

The JB4-HX711 is a combined Junction Board and Load Cell Amplifier designed for direct connection to multiple Wheatstone bridge sensors and load cells. With its small form factor and multi-purpose connector system, the Junction Board with Load Cell Amplifier allows for easy site installation and multi-sensor connection.

The JB4-HX711 uses a low power, low noise, 24-bit resolution amplifier for high precision measurements with programmable gain and data rates. Gain is selectable from 64 and 128 and is set in software. Data Rate is selectable but is set by default to 10Hz. Optional 80Hz is available but must be set by removing a resistor.

The JB4-HX711 Load Cell Amplifier accepts 2.6-5.5 VDC input voltage which is also used to supply the external bridge sensor. External sensor and amplifier IC have on-board filtering for stable, low noise operation. Connections are made simple through the use of 4-pin input and four 5-pin connectors mounted directly on the amplifier.

Communication is achieved by interacting with the Two-Wire interface. Simply connect the pins (SCLK and DATA) to a microcontroller or a serial interface and use readily available libraries to set gain and collect data from the amplifier. Please see SPI Interface for more information.

RoHS



FEATURES

- Single Channel
- Up to 1 to 4 load cell inputs
- 24-bit Analog to Digital Converter
- Programmable Gain of 64 and 128
- 10Hz Default Data Rate (80Hz optional)
- 2.6 – 5.5 VDC Supply Voltage
- Low Power Operation with Power Down Mode
- Simple Connection (4/5 pin Connector)

INTERFACE

- 4 Wire SPI

APPLICATIONS

- Weighing Scales
- Industrial Process Control
- Portable Instrumentation
- Smart Transmitters

AVIALABLE ACCESORIES

- 5 pin Sensor Cable
- 4 pin Data Cable
- Mounting Hardware

ELECTRICAL PARAMETERS

Parameter	Value	Unit
Power Supply Voltage (VCC)	2.6 – 5.5	V
No Load Cell Current	1.5	mA
Power Down Current	0.5	uA
Common Mode Input	GND + 1.2 VCC – 1.3	V V
Output Settling Time	400	ms
Input Offset Drift (Gain = 128)	0.2	mV
Temperature Drift (Gain = 128)	±5	ppm/°C
Input Common Mode Rejection (Gain = 128)	100	dB
Power Supply Rejection (Gain = 128)	100	dB

COMMUNICATIONS

The JB4-HX711 utilizes a load cell amplifier simple two-wire interface which can be connected directed to a microcontroller.

When data is not ready, DOUT is kept high and SCK is low. When data is ready DOUT set low. Data can then be retrieved by clocking in 25-27 clock pulses on the SCK pin. Each clock pulse shifts out one bit starting with the MSB until all 24 bits are shifted. The 25th clock pulse will pull DOUT back to high.

The last clock cycles indicates the Gain selection for the next conversion cycle. The Gain can be selected as shown in the table below. There must be no less than 25 and no more than 27 clock pulses in one conversion cycle to ensure proper operation of the serial interface. The first conversion after Reset will always be with a Gain of 128.

CONNECTION

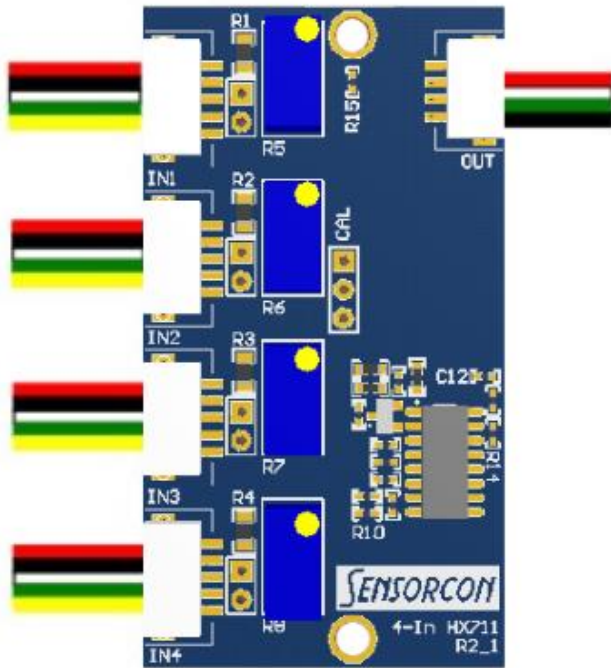

SCK Clock Pulses	Gain
25	128
27	64

Third party libraries are available for simple communication for JB4-HX711 amplifier. Please contact our sales representative for references

POWER DOWN MODE

The JB4-HX711 can be placed into power down mode by keeping SCK pin high for more than 60us. By returning the SCK to low, the amplifier will reset and resume normal operation. During low power mode, the external bridge sensor and the amplifier for minimal power consumption.

RED	Excitation +	RED	VCC
BLACK	Excitation -	WHITE	DOUT
WHITE	Output -	GREEN	SCK
GREEN	Output +	BLACK	GND
YELLOW	Shield		

In most applications, the Shield cable is left open and not connected to the load cell.